

SCR312L



25.5" x 17" x 18.5" (H x W x D)

Commercially approved countertop beverage cooler with glass door, black cabinet, front lock, and digital thermostat; replaces SCR310L

Highlights:

Commercially approved for storage of beverages and sealed goods

Factory installed lock provides security you can count on

Digital thermostat with convenient external location for easy temperature control

Interior LED lighting for an elegant display with energy efficiency

Product Features:

Commercially approved	ETL-S listed to NSF-7 commercial standards
Fully finished black cabinet	Allows the unit to be used freestanding
Double pane tempered glass door	Heat resistant design provides clear view of stored products, with an elegant trim in stainless steel
Professional handle	17 1/2" long handle in brushed aluminum
Factory installed lock	Keep contents secure with a front lock on the door
Automatic defrost	No-frost convenience for reduced user maintenance
Digital thermostat	Precise temperature management at the touch of a button, with an external display for added convenience
Interior LED light	Externally located button turns this light on and off to illuminate the products for a tempting view
Adjustable chrome shelves	Rearrange the refrigerator space to fit any sized item or remove shelves for simple cleanup



SCR312L Specifications:

Overview	
Height	25.5"
Height to Hinge Cap	26.13"
Width	17.0"
Depth	18.5"
Depth with Handle	20.25"
Depth with door at 90°	34.5"
Capacity	2.5 cu.ft.
Defrost Type	Automatic
Door	Glass
Cabinet	Black
US Electrical Safety	ETL
Canadian Electrical Safety	ETL-C
Sanitation	ETL-S
Amps	1.3
Voltage/Frequency	115 V AC/60 Hz
Weight	80.0 lbs.
Shipping Weight	100.0 lbs.
Parts & Labor Warranty	1 Year
Compressor Warranty	5 Years
Refrigerator Features	
Door Swing	RHD
Reversible	No
Shelf Type	Wire
Shelf Qty	4
Adjustable Shelves	Yes
Thermostat Type	Digital
Refrigerant Type	R134a
Refrigerant Amount	1.82
High Side PSI	270.0
Low Side PSI	103.0
Level Legs Qty	2
Interior Light	Yes
Dimensions	
Interior Height	21.25"
Interior Width	14.0"
Interior Depth	14.63"
Compressor Step Height	7.5"

Compressor Step Width	14.0"
Compressor Step Depth	5.0"

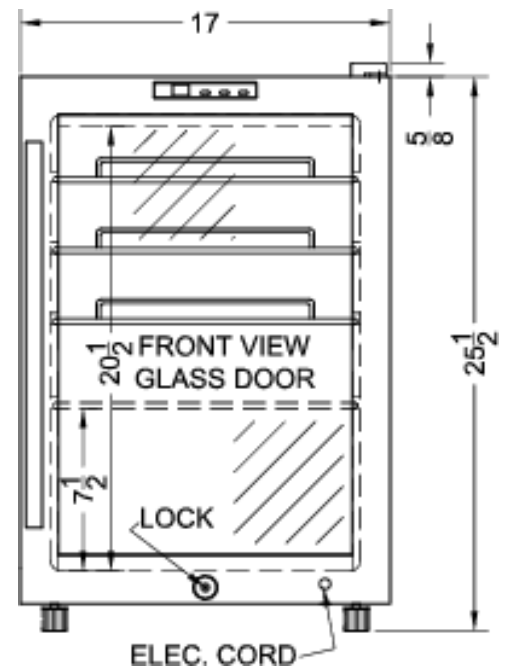
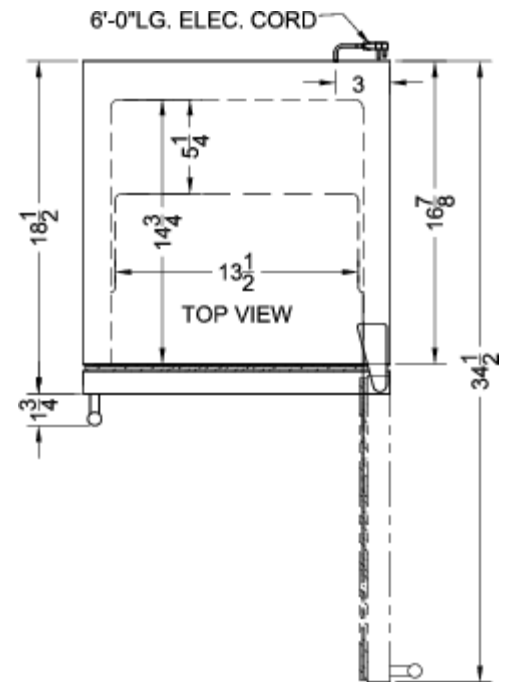

SUMMIT APPLIANCE DIVISION FELIX STORCH, INC.

770 Garrison Avenue, Bronx, NY 10474 USA TEL 718-893-3900 FAX 844-478-8799 info@summitappliance.com www.summitappliance.com