

Technical data sheet for

## E32D5 ON THE SK32 STAND

Full Size Digital / Electric Convection Oven  
on a Stainless Steel Stand



E32D5 OVEN



**d**

### E32D5

Unit shall be a Moffat electrically heated Turbofan convection oven E.T.L. listed and NSF-4 listed. The oven shall have a one piece porcelain enameled oven chamber, stainless top and sides and safe touch vented easy clean side hinged door that offers field reversible hinging. Oven shall have capacity for five full size sheet pans. The oven shall be controlled by an electronic control having separate digital displays and adjusting knobs for time and temperature functions. The oven control shall allow both manual and programmed operating modes with programmable moisture level injection and 2 speed oven fan. A core temperature probe M236060 is optional. The unit shall include dual halogen oven lamps. Oven shall be able to be bench mounted on 3" / 76mm feet or mounted on oven stand model SK32. Unit shall be supplied in 100% recyclable shipping packaging. This unit shall be Energy Star certified.

### SK32

Unit shall be a Moffat Turbofan stainless steel oven stand NSF-4 listed. The stand shall be constructed from stainless steel tube with castors, with front castors having dual swivel and wheel locks. It shall be fitted with 6 tray runners suitable for up to 12 half size sheet pans or 6 full size sheet pans. The stand shall be fully compatible with, and support, Turbofan Convection Oven models E32D and G32D. Unit shall be supplied in 100% recyclable shipping packaging.

### STANDARD FEATURES

- 5 full size sheet pan capacity
- 3½" / 85mm tray spacing
- Compact 28⅞" / 735mm width
- Digital display Time and Temperature Controls
- Large easy view ¾" / 20mm high displays
- Electronic thermostat control
- Electronic timer with countdown or time count modes
- Manual mode and Program mode
- 20 programs with 3 stage cooking and stage end alarms
- Core Probe program cooking (optional Core Probe Kit)
- Moisture injection mode (5 levels) and manual injection
- 2 speed bi-directional reversing fan system
- 6.3kW heating (220-240V) / 5.6kW heating (208V)
- Safe-Touch vented side hinged door (standard LH hinge). Optional RH hinge (field convertible)
- Stay-Cool door handle
- Porcelain enameled oven chamber
- Plug-in continuous oven door seal
- Dual halogen oven lamps
- Anti-skid 2" / 50mm dia. 3" / 76mm high adjustable stainless steel feet
- 5 oven wire racks supplied
- 100% recyclable packaging

### ACCESSORIES

- Optional M236060 Core Temperature Probe Kit
- Turbofan SK32 Oven Stand
- DSK32 Double Stacking Kit

### E32D5 Full Size Digital / Electric Convection Oven - 2 speed fan on a Stainless Steel Stand

#### CONSTRUCTION

Porcelain enameled fully welded oven chamber  
Stainless steel front, sides and top exterior  
Stainless steel oven fan baffle and oven vent  
Removable 5 position stainless steel side racks  
Oven racks chrome plated wire (5 supplied)  
Stainless steel frame side hinged door  
0.2" / 5mm thick door outer glass  
0.2" / 5mm thick low energy loss door inner glass  
Full stainless steel welded door handle  
Stainless steel control panel  
Aluminized coated steel base and rear panels

#### CONTROLS

Electronic controls with Digital Time and Temperature display, Manual or Program modes  
Large ¾" / 20mm high LED displays  
Two individual time and temperature setting control knobs  
6 function keys  
ON/OFF key  
Fan LO speed key  
Timer Start/Stop key  
Moisture injection key (5 levels)  
Programs select key  
Actual temperature display key  
Adjustable buzzer/alarm volume  
Thermostat range 150-500°F / 50-260°C  
Timer range from 180 minutes in countdown mode  
Timer range up to 999 minutes in time count mode for holding, slow cooking  
Over-temperature safety cut-out

#### CLEANING

Stainless steel top and side exterior panels  
Porcelain enameled oven chamber  
Fully removable stainless steel oven side racks  
Removable stainless steel oven fan baffle  
Easy clean door system with hinge out door inner glass (no tools required)  
Removable plug-in oven door seal (no tools required)  
3" / 76mm high stainless steel feet for easy access underside

#### SPECIFICATIONS

##### Electrical Requirements

208V, 60Hz, 1-phase, 5.8kW, 28A  
220-240V, 60Hz, 1-phase, 6.5W, 27A  
No cordset supplied

##### Water Requirements (optional)

Cold water connection ¾" GHT male  
80psi maximum inlet pressure / 20psi minimum inlet pressure

##### External Dimensions

Width 28 7/8" / 735mm  
Height 28 3/4" / 730mm including 3" / 76mm feet  
Depth 31 7/8" / 810mm

##### Oven Internal Dimensions

Width 18 1/4" / 465mm  
Height 20 1/4" / 515mm  
Depth 27 1/2" / 700mm  
Volume 6ft³ / 0.17m³

##### Oven Rack Dimensions

Width 18" / 460mm  
Depth 26" / 660mm

##### Nett Weight (E32D5)

196lbs / 89kg

##### Packing Data (E32D5)

231lbs / 105kg  
20.1ft³ / 0.57m³  
Width 29 7/8" / 760mm  
Height 32" / 815mm  
Depth 36 3/8" / 925mm

### SK32 Stainless Steel Stand

All stainless steel welded frame oven stand for Turbofan E32D, E32T and G32D Series ovens  
6 position tray runners standard  
3" / 76mm diameter wheel swivel castors standard with 2 front castors with dual swivel and wheel  
Welded 1 1/2" and 1 1/4" square tube front and rear frames  
Welded rack supports/side frames  
4 dia. 3" / 76mm swivel castors with 2 front castors dual wheel and swivel lock  
Top frame oven supports suit Turbofan E32D, E32T and G32D Series oven mounting  
Supplied CKD for assembly on site

##### External Dimensions (SK32 Oven Stand)

Width 28 7/8" / 735mm  
Height 34 5/8" / 880mm  
Depth 25 5/8" / 650mm

##### Nett Weight (SK32 Oven Stand)

40lbs / 18.5kg

##### Packing Data (SK32 Oven Stand)

51lbs / 23kg  
3.5ft³ / 0.1m³  
Width 32 5/8" / 830mm  
Height 35 1/2" / 900mm  
Depth 6" / 152mm

##### INSTALLATION CLEARANCES

Rear 2" / 50mm  
LH Side 2" / 50mm  
RH Side\* 3" / 75mm

\* For fixed installations a minimum of 20" / 500mm is required for service

##### CLEARANCE FROM SOURCES OF HEAT

A minimum distance of 12" / 300mm from the appliance sides is required



www.moffatusa.com  
www.turbofanoven.com

#### U.S.A.

Moffat Inc  
3760 Industrial Drive, Suite B  
Winston-Salem  
NC 27105-2637  
Ph Toll Free 1-800-551 8795  
Ph 336-661 0257  
Fax 336-661 9546  
Email sales@moffat.com  
www.moffatusa.com

#### Manufactured by:

Moffat Limited  
45 Illinois Drive, Izone Business Hub  
Rolleston 7675, New Zealand



ISO9001  
Quality  
Management  
Standard

Designed and manufactured by



#### ISO9001

All Turbofan products are designed and manufactured by Moffat using the internationally recognised ISO9001 quality management system, covering design, manufacture and final inspection, ensuring consistent high quality at all times.

In line with policy to continually develop and improve its products, Moffat Limited reserves the right to change specifications and design without notice.



E32D5 OVEN

© Copyright Moffat Ltd  
US.TF.N.S.1701

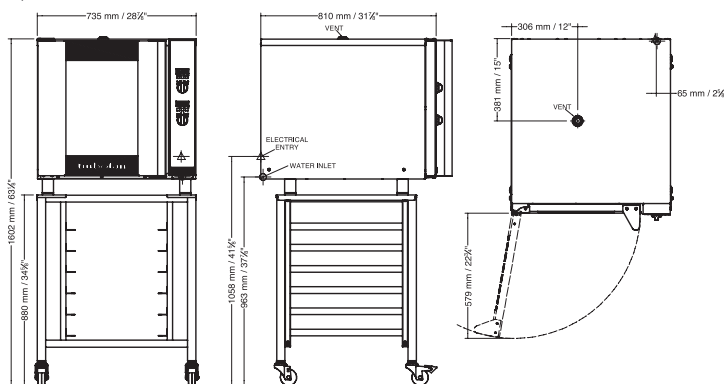

an Ali Group Company



The Spirit of Excellence