



REFRIGERATION

SERVING THE FOOD INDUSTRY SINCE 1951

FLOOR MODEL REFRIGERATED DISPLAY CASES - 18 CU.FT CAPACITY

Item: 50077
Model: RS-CN-0120-B

Item: 50079
Model: RS-CN-0120-S

These Omcan's refrigeration units are the perfect blend of reliable and visually appealing. Keep your products fresh and in clear view of your customers with these floor model refrigerated display cases. These units give you a spacious 18 cu.ft of capacity. Bring these to your supermarket, convenience store or deli to help with impulse sales. The design will suit many establishments and keep up with all the demands of day-to-day service.



WARRANTY
PARTS AND LABOR



NEMA
5 - 15
125 VAC / 15 AMP



Authorized Dealer

REFRIGERATION

FLOOR MODEL REFRIGERATED DISPLAY CASES - 18 CU.FT CAPACITY

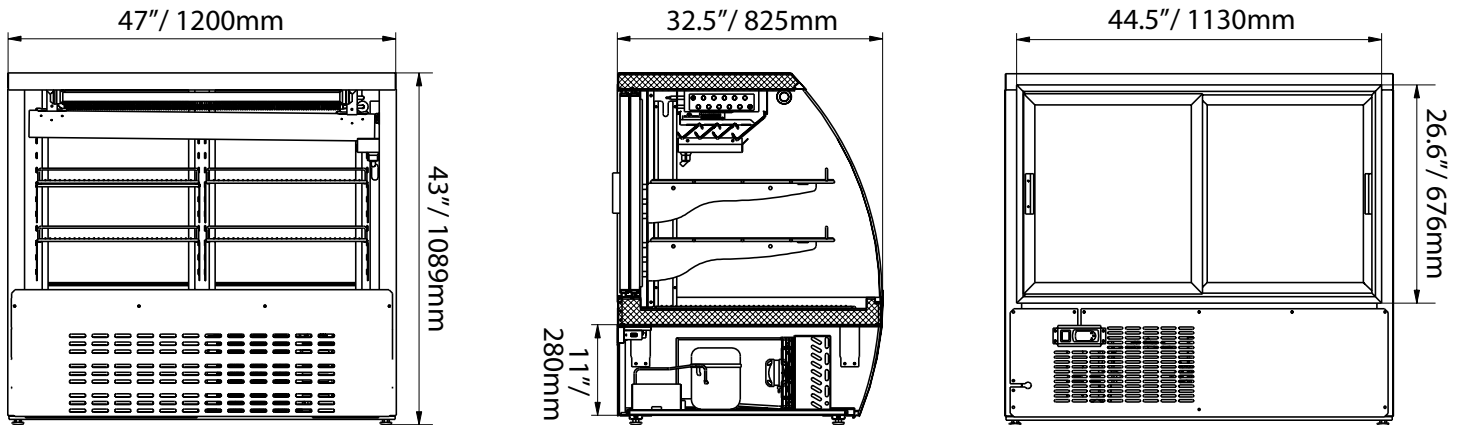

Features:

- Interior: Aluminum liner with stainless steel floor
Exterior: Black coated steel for item 50077 and stainless steel for item 50079
- Attractive curved glass with rear sliding glass doors
- Rounded corner design inside of the cabinet makes storage room easy to clean
- Temperatures range: 32° - 43° (0° - 6°)
- Removable installation board for easy cleaning and service
- Shelves: Adjustable heavy-duty PVC coated shelves
- LED interior lighting
- Gravity coil refrigeration system to avoid drying up and preservation of food products
- Power cord length 7'7" / 2311.4 mm

TECHNICAL SPECIFICATION

ITEM NUMBER	50077	50079
MODEL	RS-CN-0120-B	RS-CN-0120-S
DESCRIPTION	Black floor model refrigerated showcase	Stainless steel floor model refrigerated showcase
TEMPERATURE RANGE	0 - 6°C/ 32 - 43°F	
POWER	1/4+	
ELECTRICAL	115V/60Hz/1Ph	
AMPS	2.6	
CAPACITY	508L/ 18 cu.ft	
REFRIGERANT	R290	
NET DIMENSIONS (WDH)	47" x 32.5" x 43" / 1200 x 825 x 1089 mm	
GROSS DIMENSIONS	52" x 37" x 49" / 1320 x 940 x 1240 mm	
NET WEIGHT	319 lbs/ 145 kgs	
GROSS WEIGHT	429 lbs/ 195 kgs	
CERTIFICATIONS	cETLus / ETL Sanitation	

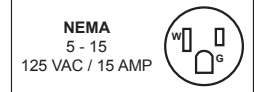

OMCAN INC.

Telephone: 1-800-465-0234
 Fax: (905) 607-0234
 Email: sales@omcan.com
 Website: www.omcan.com



Follow us to keep up to date with the latest news and offers

