



CE ISO 9001

XC212

FROZEN BEVERAGE MACHINE

The XC212 is the smallest and lightest dual bowl frozen drink machine in the world, and its compact size and light weight makes it perfect for residential or and light volume applications. The XC212 offers a mirror stainless finish with gloss black trim that accents any placement. The XC212 uses a modern and energy efficient refrigeration system that runs on a standard 115 volt outlet and includes an adjustable consistency control for easy operation and the perfect flush every time.

Features

- A compact machine with impressive performance and capacity
- Variable consistency control to accommodate different mixes and slush consistencies
- Individually operable bowls for versatility
- Dual augers in each bowl for perfect product mixing and consistency
- Dishwasher safe components for easy cleanup
- 3.2 gallon total capacity
- Removable drip tray for easy cleaning and draining

DONPER USA

Donper USA
24610 Kingsland Blvd
Katy, TX 77494

1-844-366-7371
sales@donperusa.com
www.donperusa.com

Side View

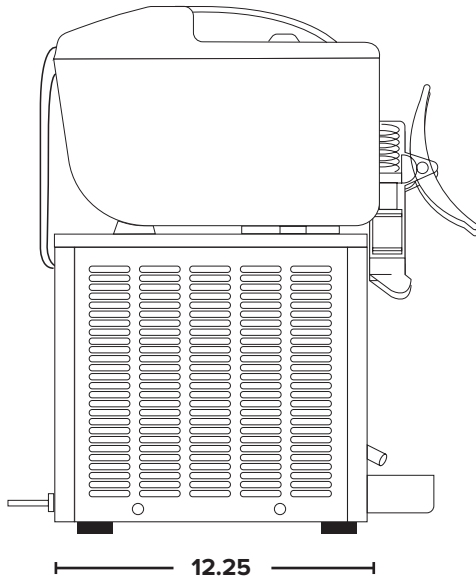

Front View

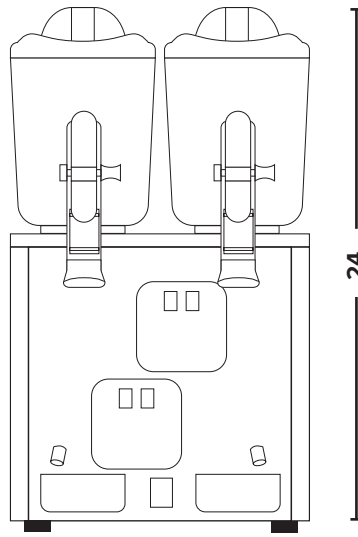

Top View

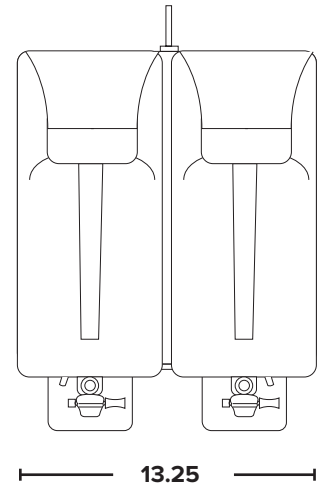

Measurements in inches.

Size and Capacity

Bowl Capacity (each)	1.6 Gal (6 L)
Height	24 in (610 mm)
Width	13.25 in (337 mm)
Depth	12.25 in (311 mm)
Weight	62 lbs (28 kg)

Electrical

Voltage	115 v
Phase	Single
Rated Input Power	7.4 A
Compressor	1/4 HP
Hertz	60 Hz
Plug type	115 volt Standard Plug

Distributed By:
