

MAXXIMUM

dispensers

COMMERCIAL HI-PERFORMANCE DISPENSERS

Project Name: _____

Location: _____

Item #: _____

Qty: _____

Model #: _____

DISPENSERS

SPECIFICATIONS

MODEL MSD10 - A powerful 1/3 horsepower motor and compact design that measures 24" x 17" x 8". Consumption in volts is 110/60, 220/50, 220/60 and consumption in watts is 300. Shipping weight is 42 lbs.

MODEL MSD20 - A powerful 1/3 horsepower motor and compact design that measures 24" x 17" x 16". Consumption in volts is 110/60, 220/50, 220/60 and consumption in watts is 420. Shipping weight: 69 lbs.

MODEL MSD30 - A powerful 1/3 horsepower motor and compact design that measures 24" x 17" x 24". Consumption in volts is 110/60, 220/50, 220/60 and consumption in watts is 500. Shipping weight: 86 lbs.

STANDARD FEATURES

Visual - The product is displayed in a clear transparent container to generate appetite appeal and help you sell more product.

Compact Design- MAXX SERVE was designed to use as little counter top space as possible and to be able to fit in virtually any environment. This enhances its profitability.

Service - Every MAXX SERVE is carefully designed and engineered to ensure optimum performance and more running time. It is easy to clean and maintain retaining its appeal to your customers.

Engineered to be the Best - Each MAXX SERVE drink dispenser is uniquely designed to adapt to your needs. This versatility means you can attract more customers with their favorite drinks. The unique evaporator and extra large pump cools more efficiently thereby reducing energy consumption. Its stainless steel cylinder, frame and front panel provide extra long life as well as easy cleaning.

Consistency - MAXX SERVE's rotary system continuously circulates the product to ensure a fresh and consistent drink every time.



MSD10
One 3 Gallon Bowl



MSD20
Two 3 Gallon Bowls



MSD30
Three 3 Gallon Bowls



Specifications subject to change without notice.

Approvals:

MAXXIMUM

HIGH PERFORMANCE PRODUCTS

COMMERCIAL HI-PERFORMANCE DISPENSERS

15712 SW 41st Street • Suite 8 • Ft. Lauderdale, FL 33331

Tel: (954) 202-7419 • Fax: (954) 202-7337

www.asburyfoodservice.com

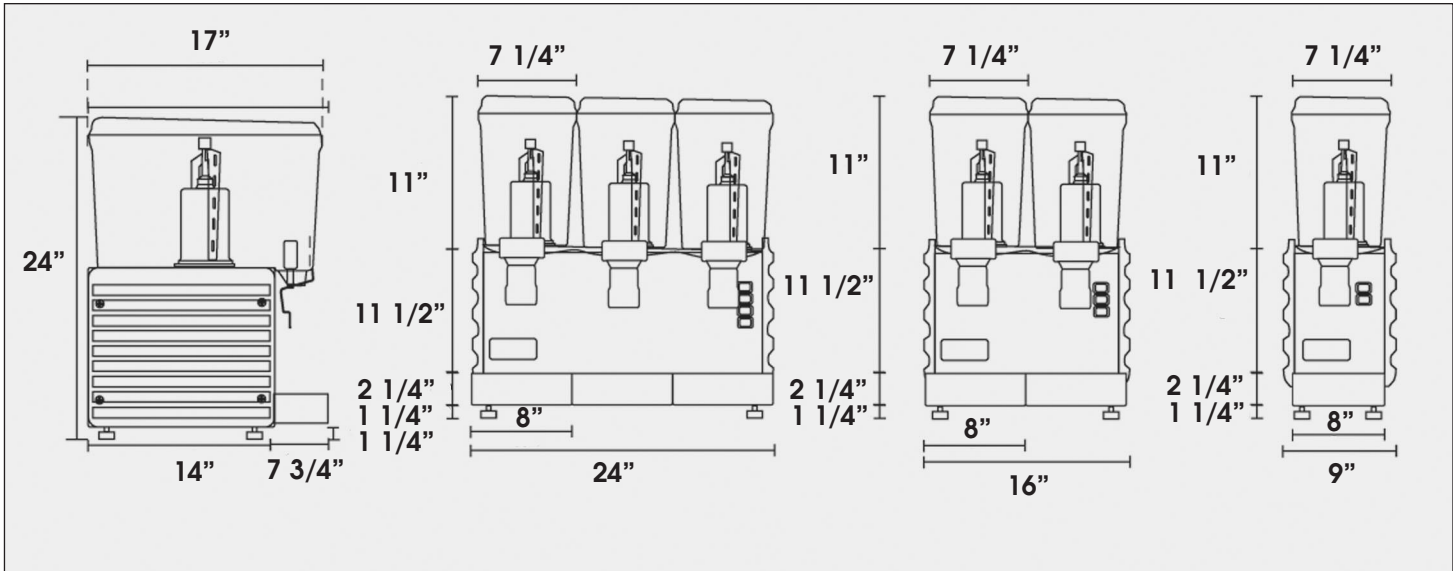

STANDARD FEATURES

Visual - The product is displayed in a clear transparent container to generate appetite appeal and help you sell more product.

Compact Design- MAXX SERVE was designed to use as little counter top space as possible and to be able to fit in virtually any environment. This enhances its profitability.

Service - Every MAXX SERVE is carefully designed and engineered to ensure optimum performance and more running time. It is easy to clean and maintain retaining its appeal to your customers.

Engineered to be the Best - Each MAXX SERVE drink dispenser is uniquely designed to adapt to your needs. This versatility means you can attract more customers with their favorite drinks. The unique evaporator and extra large pump cools more efficiently thereby reducing energy consumption. Its stainless steel cylinder, frame and front panel provide extra long life as well as easy cleaning.

Consistency - MAXX SERVE's rotary system continuously circulates the product to ensure a fresh and consistent drink every time.