



PROJECT

ITEM NO:

QUANTITY:

Stainless Steel Work Tables

Open Base With Galvanized Legs & Cross-Bars



NSF STD.2
Certified

FEATURES & CONSTRUCTION:

- Top is fabricated with 1-1/2" rounded edge on both working sides and flat edge on both ends.
- Table top edges formed with hemmed edges to provide extra rigidity and safe to touch finish.
- Reinforced table top with two galvanized steel sound deadening hat channels. Note: Three sound deadening hat channels on 30" & 36" deep tables.
- All exposed welded areas smooth polished to brush finish sanitary #4.
- Adjustable galvanized steel cross-bars with aluminum die cast fittings to secure cross-bars to legs for added stability.
- Welded galvanized steel leg sockets with two point leg fastening.
- All tables shipped K.D., but easily assembled.



* 84" tables and longer come with 6 legs

MATERIAL:

Top: 18 Gauge Stainless Steel - 400 series

Cross-Bar: 1-1/4" Galvanized Steel Tubing

Leg: 1-5/8" Galvanized Steel Tubing with 1" Adjustable Plastic Bullet Feet

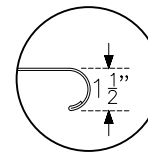

Rolled Rim Edge
Front And Rear
Reinforced with
Hemmed Edge

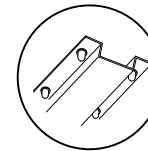

Two (three on 30" & 36" deep) Hat Channel Reinforced Top. Attached to Underside of Top via Studs Welded to Underside of Top, Adhesive and Stainless Steel Acorn Nuts.



Aluminum Die Cast Fitting For Adjustable Cross-Bar



Plastic Bullet Feet
1" Adjustable

Open Base Table With Galvanized Cross-bar & Legs

W	14"	18"	24"	30"	36"
L	MODEL NO.				
24"	SMTO-1424G	SMTO-1824G	SMTO-2424G	SMTO-3024G	SMTO-3624G
30"	SMTO-1430G	SMTO-1830G	SMTO-2430G	SMTO-3030G	SMTO-3630G
36"	SMTO-1436G	SMTO-1836G	SMTO-2436G	SMTO-3036G	SMTO-3636G
48"	SMTO-1448G	SMTO-1848G	SMTO-2448G	SMTO-3048G	SMTO-3648G
60"	SMTO-1460G	SMTO-1860G	SMTO-2460G	SMTO-3060G	SMTO-3660G
72"	SMTO-1472G	SMTO-1872G	SMTO-2472G	SMTO-3072G	SMTO-3672G
84"	SMTO-1484G	SMTO-1884G	SMTO-2484G	SMTO-3084G	SMTO-3684G
96"	SMTO-1496G	SMTO-1896G	SMTO-2496G	SMTO-3096G	SMTO-3696G
108"	SMTO-14108G	SMTO-18108G	SMTO-24108G	SMTO-30108G	SMTO-36108G
120"	SMTO-14120G	SMTO-18120G	SMTO-24120G	SMTO-30120G	SMTO-36120G



Rev. 01/21

SAPPHIRE MANUFACTURING
Tel: 718-543-2111
Fax: 718-543-2121

info@sapphiremanufacturing.com
WWW.SAPPHIREMANUFACTURING.COM



PROJECT

ITEM NO:

QUANTITY:

Stainless Steel Work Tables

Open Base With Galvanized Legs & Cross-Bars



NSF STD.2
Certified

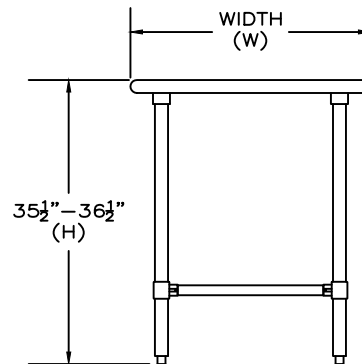
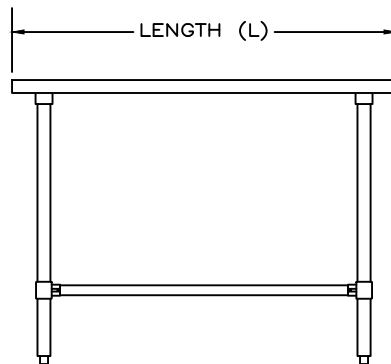
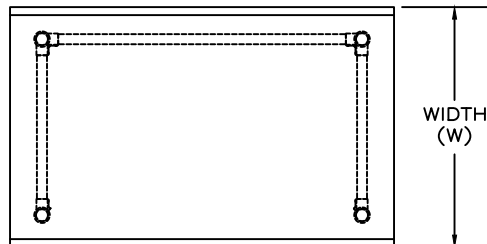

35½"–36½"
(H)

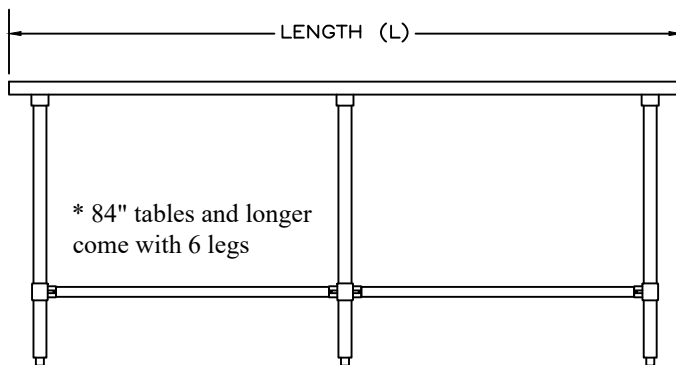
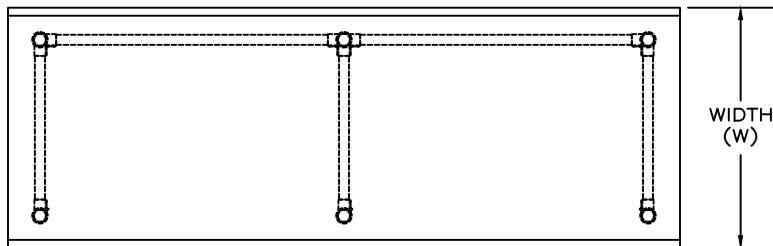

* 84" tables and longer
come with 6 legs

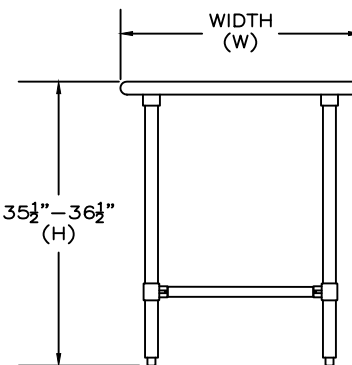

35½"–36½"
(H)

Specifications subject to change without notice.

All dimensions are typical (Tolerance 1/2").



Rev. 01/21

SAPPHIRE MANUFACTURING
Tel: 718-543-2111
Fax: 718-543-2121

info@sapphiremanufacturing.com
WWW.SAPPHIREMANUFACTURING.COM