



PROJECT

ITEM NO:

QUANTITY:

## Sheet Pan Racks

### SMAPR-10KD

#### FEATURES & CONSTRUCTION:

- Aluminum half height sheet pan rack.
- Capacity: (10) full-size 18"x26" or (20) half-size 18"x13" sheet pans, 3" spacing.
- Four 5" swivel rubber casters, Two with brakes.
- All units shipped K.D., but easily assembled.



NSF STD.2  
Certified

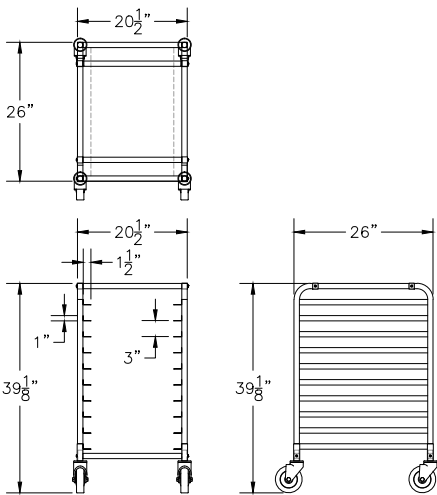

### SMAPR20KD

#### FEATURES & CONSTRUCTION:

- Aluminum full height sheet pan rack.
- Capacity: (20) full-size 18"x26" or (40) half-size 18"x13" sheet pans, 3" spacing.
- Four 5" swivel rubber casters, Two with brakes.
- All units shipped K.D., but easily assembled.



NSF STD.2  
Certified

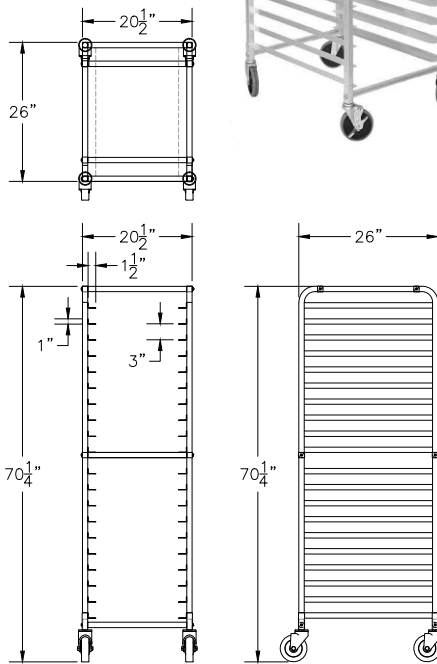

### SMAES-10

#### FEATURES & CONSTRUCTION:

- Aluminum solid top half height sheet pan rack.
- Capacity: (10) full-size 18"x26" or (20) half-size 18"x13" sheet pans, 3" spacing.
- Four 5" swivel rubber casters, Two with brakes.
- All units shipped K.D., but easily assembled.



NSF STD.2  
Certified

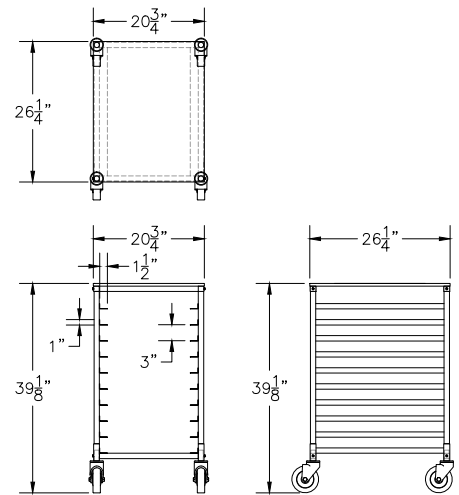

Specifications subject to change without notice.

All dimensions are typical (Tolerance 1/2").



Rev. 10/22

SAPPHIRE MANUFACTURING  
Tel: 718-543-2111  
Fax: 718-543-2121

info@sapphiremanufacturing.com  
WWW.SAPPHIREMANUFACTURING.COM